



PAKISTAN ENGINEERING COUNCIL

Sample MCQs

Electrical Engineering (Computer)/ Computer Engineering

1. Please read all the instructions carefully and do not start the paper unless asked to do so.
2. Fill in your particulars (Name, Roll Number, PEC Registration Number, CNIC and Discipline) in BLOCK letters in the space provided.
3. You are not allowed to change your seat during the test.
4. Hand over your answer sheet to the invigilator at the end of each part and keep seated until allowed to leave the centre.
5. The examination is divided into three Parts viz Part-I, Part-II and Part-III, with 30 minutes break.
6. All questions are to be attempted and carry equal marks.
7. Passing marks for each part is 60%, and passing all three parts is mandatory to qualify EPE.
8. Use only the provided pencil to fill completely the correct choice circle on answer sheet.
9. Programmable calculator, laptop, mobile phone, iPod, and any storage device/electronic gadget are not allowed.
10. No extra sheet will be provided; any calculation may be worked out on the back of the paper.
11. No candidate is allowed to indulge in any Law and Order situation to affect the exam process, and responsible(s) will be disqualified.
12. Use of unfair means will also lead to disqualification.

Instructions for Part-I

This part is common to all disciplines, comprising 30 multiple choice questions of one mark each (Total Marks=30) with the duration of two hours.

Instructions for Part-II

This is a discipline based open book breadth examination, comprising 30 multiple choice questions of one mark each (Total Marks=30), with the duration of two hours.

Instructions for Part-III

This is a discipline based open book depth examination comprising 40 multiple choice questions of one mark each (Total Marks=40), with duration of three hours. The candidates will be allowed only for the specialized field / area of practice, for which already applied at the time of application.

Electrical Engineering (Computer)/ Computer Engineering

Part-I

Total Marks: 30

Total Time: 2 hours

Name:	S/o, D/o, w/o:
Roll Number:	PEC Reg#:
CNIC:	Discipline:

Q.1: Quality control is aimed at:

- a. Maintaining the desired quality
- b. Exceeding the desired quality
- c. Continuously improving the quality
- d. Following the quality

Q.2: Which of these is correct with respect to a product developed or a service performed?.

- a. Bad quality is acceptable, but bad grade is not.
- b. Bad grade is acceptable, but bad quality is not.
- c. Neither bad grade nor quality is acceptable.
- d. Grade and quality is the same thing.

Q.3: Project A has an internal rate of return (IRR) of 21 percent. Project B has an IRR of 7 percent. Project C has an IRR of 31 percent. Project D has an IRR of 25 percent. Which of these would be the BEST project?

- a. Project A
- b. Project B
- c. Project C
- d. Project D

Q.4: What characteristic best describes the cost baseline?

- a. Total budget for the project
- b. Time phased budget for the project
- c. Total budget for the project including the contingency budget

- d. Total budget for the project including the contingency budget and the management reserve.

Q.5: Present worth is:

- a. The discounted future cash flows to the present
- b. The compounding present cash flows to the future
- c. The current market value of the investment
- d. The opportunity cost at the present value.

Q.6: The first preferred way to resolve a dispute between the contracting parties is:

- a. Arbitration
- b. Litigation
- c. Negotiation
- d. Mediation

Q.7: Following document define the legal rights and obligations of the parties and may be described as the regulations under which the contract will be performed.

- a. Specifications
- b. General Conditions of Contract
- c. Special provisions
- d. Bill of Quantities

Q.8: The minimum notice period for National Competitive bidding is:

- a. 30 days
- b. 45 days
- c. 35 days
- d. 15 days

Q.9: Tsunamis' is generated by:

- a. Earthquake
- b. Air currents
- c. Tidal waves
- d. Large Ocean waves

Q.10: Globalization has direct impact on:

- a. National security
- b. Economy
- c. Society
- d. All above

Q.11: The passive voice for the sentence "He is writing a letter" is;

- a. A letter is wrote by him
- b. A letter is written by him
- c. A letter is being written by him
- d. A letter is been written by him

Q.12: Choose the correct sentence

- a. He is elder than me
- b. He is older than me
- c. He is ager than me
- d. He is older than I

Q.13: Effective communication is

- a. The transfer of message from sender to receiver
- b. Sending of message
- c. Receiving of message
- d. The transfer of message from sender to receiver and get the desired response.

Q.14: Body language is form of;

- a. Personality and attitudes
- b. Non verbal communication
- c. Individual preference for expression
- d. The body expression

Q.15: Project feasibility report is aimed at;

- a. Informing the people
- b. Attracting the customer
- c. Justifying the investment
- d. Giving details of resources

Q.16: Research Proposal synopsis is developed at;

- a. Final stage of research
- b. Initial stage of research
- c. Before approval of research proposal
- d. In the middle of research

Q.17: Project monitoring is required:

- a. Before commencement of the project
- b. During implementation of the project
- c. After completion of the project
- d. At any stage of the project deemed necessary

Q.18: Re-appropriation Statement is form of

- a. Progress report
- b. Budget report
- c. Financial report
- d. Normal report

Q.19: PC-III (A) is used for

- a. For weekly progress report of public sector projects
- b. Monthly progress report of public sector projects
- c. Yearly progress report of public sector projects
- d. Quarterly progress report of public sector projects.

Q.20: Acquiring management and leadership skills are _____ for a Professional Engineer

- a. Wastage of time
- b. Not important
- c. Highly important
- d. Not necessary

Q.21: Engineering ethics refers to:

- a. The rules and standards given by an institution for Engineering practice
- b. The rules and regulation relating to obligations and rights of others.
- c. The professional regulation
- d. The rules and standards which govern the conduct of Engineers as professional Engineers.

Q.22: How many commandments are given in PEC Code of Ethics?

- a. 20
- b. 30
- c. 10
- d. 05

Q.23: As per PEC Code of Conduct a member shall report unethical professional practices of an engineer or a member with substantiating data to

- a. Court of Law
- b. Concerned Department
- c. Pakistan Engineering Council
- d. Law enforcing Agency

Q.24: When a member uses designs, plans, specifications, data and notes supplied to him by a client or an employer or are prepared by him in reference to such client or the employer's work such designs, plans, specifications, data and notes shall remain the property of the _____ and shall not be duplicated for any use without the express permission of the _____.

- a. Member, Member
- b. Client, Client
- c. Member, Client
- d. Client, Member

- Q.25:** As per PEC Code of Conduct to maintain, uphold and advance the honor and dignity of the engineering professional, a member shall do following except:
- uphold the ideology of Pakistan
 - be honest, impartial and serve the country, his employer, clients and the public at large with devotion.
 - Uphold personal interest first
 - use his knowledge and skill for the advancement and welfare of mankind
- Q.26:** Conflicts are faced when:
- There are more than one expected outcomes
 - There are more than one expected benefits and losses
 - There is choice between two or more moral values each having its own merits.
 - There are opposing outcomes.
- Q.27:** An example of a conflict of interest would be:
- As a responsible official you make a decision about a contract award that will benefit you personally
 - You and a functional manager disagree with a task cost estimate
 - Your sponsor decides to cancel your project because it no longer supports the company strategy
 - Your personality conflicts with that of a key member of your project team.
- Q.28:** Adherence to professional ethics is _____ an engineer to society.
- Not obligation of
 - An obligation of
 - Optional for
 - None of above
- Q.29:** While designing a project by an engineer, _____ should be taken into account to protect cultural heritage
- All possible alternates
 - No protection
 - Minimum protection
 - No care
- Q.30:** Close interpersonal relationships are characterized by high intimacy whereas distressed relationships tend to involve reciprocation of _____ behaviour.
- positive
 - negative
 - normal
 - casual

Answers:

1. a
2. b
3. c
4. b
5. a
6. c
7. a
8. d
9. a
10. d
11. c
12. b
13. d
14. b
15. c
16. c
17. b
18. c
19. b
20. c
21. d
22. c
23. c
24. b
25. c
26. c
27. a
28. b
29. a
30. b

Part-II (Breadth of discipline)

Total Marks: 30

Total Time: 2 hours

Q.1: Which of the following is a hyperbola ?

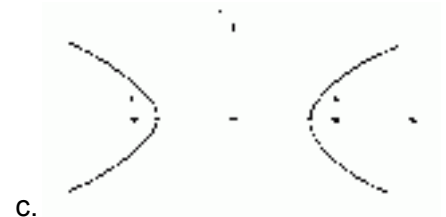
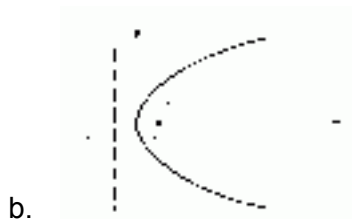
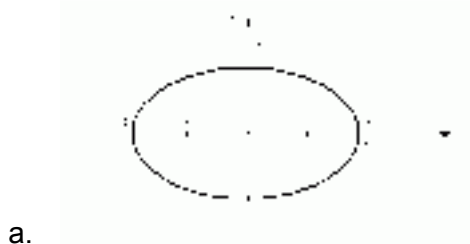

d. None of the above

Q.2: Integrating $\int \frac{\ln\left(\frac{1}{x}\right)}{x^2} dx$ will result in

- a. $\frac{1}{x} \ln\left(\frac{1}{x}\right) - \frac{1}{x} + c$
- b. $\frac{1}{x} + c$
- c. $-\left(\frac{1}{x} \ln\left(\frac{1}{x}\right) - \frac{1}{x}\right) + c$
- d. None of the above

Q.3: An $n \times n$ matrix is said to be symmetric if;

- a. If it is equal to its transpose
- b. If its determinant is equal to zero
- c. If it is of 2nd order
- d. None of the above

Q.4: Mathematically, what is a differential?

- a. A technique used for mathematical modeling.
- b. A method of directly relating how changes in an independent variable affect changes in a dependent variable.
- c. A method of directly relating how changes in a dependent variable affect changes in an independent variable.

d. None of the above

Q.5: The maximum current will pass through

- a. Resistance
- b. Inductance
- c. Capacitance
- d. None of above

Q.6: An element which consumes energy instead of storing in it is

- a. Resistor
- b. Inductor
- c. Capacitor
- d. Conductor

Q.7: A 1000W heater is rated to operate at a direct current (DC) of 10A. If the heater is supplied alternating current (AC) for producing the same quantity of heat the value of current should be

- a. $i_{av}=10A$
- b. $I_{rms}=10A$
- c. $I_{peak}=10A$
- d. $I_{rms}=10\sqrt{2}A$

Q.8: A fixed resistance 'R' is connected across a dc voltage source. If the voltage is gradually and uniformly increased, the relationship between V and R is correctly represented in which group

- a. Fig(A)
- b. Fig(B)
- c. Fig(C)
- d. Fig(D)

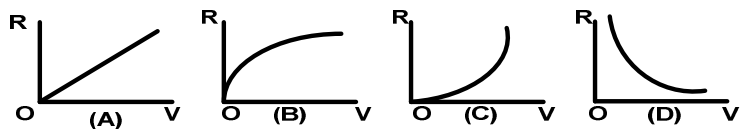

Q.9: The effects due to electric current are:

- I. Magnetic effect
- II. Heating effect
- III. Luminous effect

Application working on which effect can be used on AC as well as DC supply?

- a. I only
- b. II only
- c. II and III only
- d. I, II only

Q.10: The root locus of a unity feed-back system is shown in fig. The open loop transfer function is given by:

- a. $k/s(s+1)(s+2)$
- b. $k(s+1)/s(s+2)$
- c. $k(s+2) / s(s+1)$
- d. $ks / (s+1) (s+2)$

Q.11: A certain common-emitter amplifier has a voltage gain of 100. If the emitter bypass capacitor is removed.

- a. The circuit will become unstable
- b. The voltage gain will decrease
- c. The voltage gain will increase
- d. The circuit will become stable

Q.12: A Darlington transistor connection provides a transistor having a very large

- a. Current gain
- b. Voltage gain
- c. Impedance gain
- d. Impedance matching gain

Q.13: What is wrong with this circuit?

- a. The zener is open
- b. The zener is shorted
- c. Nothing
- d. Not enough data

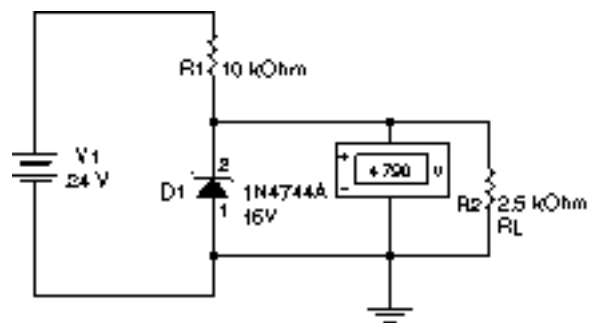

Q.14: An oscillator that uses a tapped coil to obtain the feedback is called:

- a. A Hartley circuit
- b. A Pierce circuit

- c. A multivibrator
- d. A negative feedback circuit

Q.15: If the output filter capacitor in a power supply actually had a value twice its stated value, which of the following symptoms would be found?

- a. The output voltage would be doubled and a small improvement in the ripple voltage would be detected.
- b. The ripple voltage would be half of what is expected and a small increase in the output voltage would be detected.
- c. The output and ripple voltage would be greater than expected.
- d. The output and ripple voltage would be less than expected.

Q.16: What is the simplified version of the signal flow graph represented below?

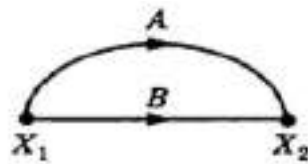

- a.) b.
- c. d.

Q.20: Frequency is inherently a physical quantity with characteristics.

- a. Positive
- b. negative
- c. both a & b
- d. none of above

Q.21: If $x(n) = \{1, 2, 5, 7, 0, 1\}$ then its region of convergence (ROC) will be:

- a. Entire plane
- b. Entire plane except $Z=0$
- c. Entire plane except $Z=0$ and $Z= \infty$
- d. None of the above

Q.22: Which losses in a transformer varies significantly with load

- a. Hysteresis losses
- b. Eddy current losses
- c. Copper losses
- d. Core losses

Q.23: Consider the circuit shown in the given figure. For maximum power transfer to the load, the primary to secondary turn's ratio must be

- a. 9 : 1
- b. 3 : 1
- c. 1 : 3
- d. 1 : 9

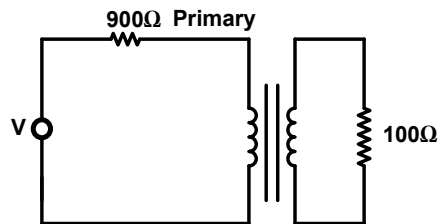

Q.24: A lamp of 100W at 200V is supplied current at 100 volts. It will be equivalent to the lamp of:

- a. 50W
- b. 40W
- c. 25W
- d. 10W

Q.25: The CPU structure contains:

- a. Cache, ALU, Control Unit and Control Memory
- b. System Bus, ALU, Control Unit and Registers
- c. Memory, ALU, Control Unit and Cache
- d. Registers, ALU, Internal CPU Interconnection and Control Unit

Q.26: Clock Speed of which Intel microprocessor is 3 GHz?

- a. Core 2 Duo
- b. Core 2 Quad
- c. Pentium 4
- d. Pentium III

Q.27: Normally, the FPGA resources are used less than 70% because:

- a. Routing becomes excessively complicated
- b. Power issues
- c. Clock frequency
- d. Simulation time increases

Q.28 In which layer Telnet and FTP works?

- a. Application
- b. Session
- c. Network
- d. Physical

Q.29: As we know when there is a joint in optical fiber then there will be some loss then this loss be minimized by

- a. Using index matching fluid in the gap
- b. Making V-grooved splicing
- c. Both (a) and (b)
- d. Making carefully polishing

Q.30: Fast fading occurs if the channel _____ changes rapidly within the symbol duration.

- a. Bandwidth
- b. Frequency

- c. Impulse response
- d. None of the above

Part-III (Depth: Computer Engineering)

Total Marks/ MCQs: 40

Total Time: 3 hours

(Sample MCQs = 20)

Q.1 The logical values used in Verilog are:

- a. 0, 1, z
- b. 0, 1, x
- c. 0, 1, x, z
- d. 1, 0

Q.2 If $b=2'b10$ and $c=\{2'b01,\{b,b\}\}$, then:

- a. $c = 6'b011010$;
- b. $c = 6'b101010$;
- c. $c = 6'b111111$;
- d. $c = 6'b001100$;

Q.3: Which of the I/O structure steals memory cycles from CPU and slows down CPU execution during its operation?

- a. Synchronous
- b. Asynchronous
- c. Direct Memory access
- d. Symmetric

Q.4: What is not true about following Resource Allocation graph?

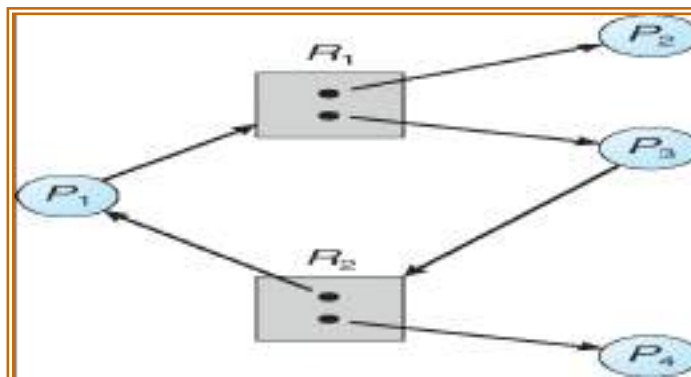

- a. This graph shows a deadlock
- b. P2 is waiting for R2
- c. This graph does not show a deadlock
- d. Both a and b above

Q.5: What would be the average waiting time for the execution of the following processes with the given burst time using Shortest Job First CPU scheduling algorithm?

PROCESS	BURST TIME
P1	6 ms
P2	8 ms
P3	7 ms
P4	3 ms

- a. 10.25 ms
- b. 7 ms
- c. 11 ms
- d. 8.5 ms

Q.6: What is represented by the question mark symbol?

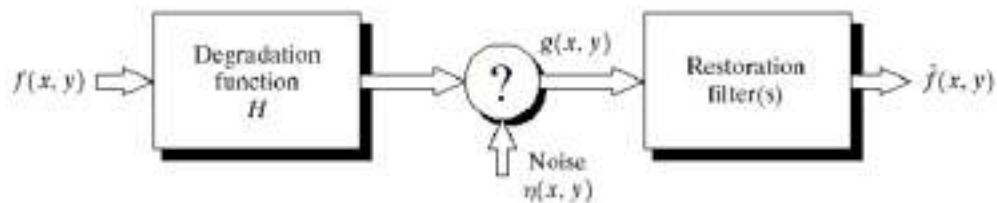

- a. -
- b. +
- c. /
- d. ×

Q.7: Consider image segment shown below. For $V=\{0, 1\}$, determine whether this image is:

3	1	2	$1_{(q)}$
2	2	0	2
1	2	1	1
$1_{(p)}$	0	1	2

- a. 4-adjacent
- b. 8-adjacent
- c. 16-adjacent
- d. 2-adjacent

Q.8: A binary image is encoded using run length code row by row, with “0” represents white, and “1” represents black. What will be code for row 10 in diagram given below?

- a. “0”, 7, 2, 7
- b. “1”, 3, 10, 3
- c. “0”, 2, 1, 10, 1, 2
- d. “0”, 3, 2, 6, 3, 2

Q.9: Difference equations show that feedback is a strong characteristic of:

- a. IIR filters
- b. Digital filters
- c. FIR filters
- d. None of the above

Q.10: This figure shows which structure? $x(n)$

- a. Lattice structure
- b. Traversal structure
- c. Cascaded structure
- d. Parallel structure

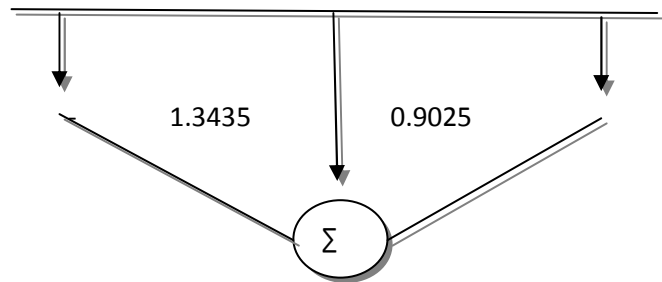

Q.11: Which protocol works at the Internet layer and provides a connection service between hosts?

- a. IP
- b. ARP
- c. TCP
- d. UDP

Q.12 How long does it take to send a file of 640,000 bits from host A to host B over a circuit-switched network?

- All links are 1.536 Mbps
- Each link uses TDM with 24 slots/sec

- 500 msec to establish end-to-end circuit

- a. 7.5 sec
- b. 8.5 sec
- c. 9.5 sec
- d. 10.5 sec

Q.13: The purpose of data flow diagrams is to provide a ----- between users and systems developers.

- a. Empty Space
- b. Data Flows
- c. Information Flows
- d. Linking Bridge

Q.14: Which of these software characteristics are used to determine the scope of a software project?

- a. Context, lines of code, function
- b. Context, function, communication requirements
- c. Information objectives, function, performance
- d. Communications requirements, performance, information objectives

Q.15: The number of people required for a software project is determined:

- a. After an estimate of the development effort is made
- b. By the size of the project budget
- c. From an assessment of the technical complexity of the system
- d. Size of the project budget and the number of experts available for the project

Q.16: Which of the following option is used to store the memory address of the next instruction?

- a. Memory Address Register
- b. Memory Data Register
- c. Instruction Register
- d. Program Counter

Q.17: What is the solution for following problem?

Increased processor speed results in external bus becoming a bottleneck for cache access.

- a. Move external cache on chip, operating at the same speed as the processor
- b. Create separate data and instruction caches
- c. Add external cache using faster memory technology
- d. Add a fast RAM

Q.18: Which option is true for Caller saving convention of saving registers?

- a. Calling procedure is saved for saving the registers it wants to use
- b. Calling procedure is responsible for saving registers
- c. Callee procedure saves the registers
- d. Calling procedure discards the contents of registers

Q.19: Consider two image subsets S_1 and S_2 , shown in the figure below. For $V=\{1\}$, determine whether these two subsets are:

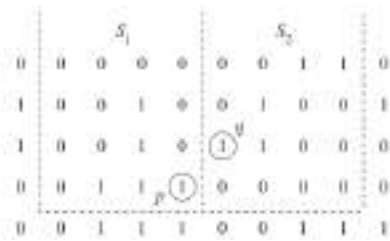

- a. 8- adjacent
- b. m-adjacent
- c. n-adjacent
- d. (a) and (b) only

Q.20: In diagram below, **?** indicates?

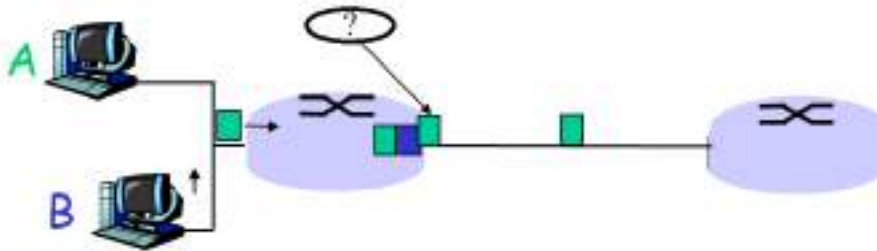

- a. Transmission
- b. Propagation
- c. Nodal processing
- d. Queuing

Answers:

1. c
2. a
3. c
4. d
5. b
6. b
7. a
8. c
9. a
10. b
11. a
12. d
13. d
14. c
15. a
16. d
17. a
18. b
19. c
20. a

Answers:

1. c
2. c
3. a
4. c
5. c
6. a
7. b
8. a
9. c
10. a
11. b
12. a
13. a
14. a
15. b
16. b
17. c
18. a
19. c
20. a
21. c
22. c
23. a
24. c
25. d
26. b
27. a
28. a
29. a
30. c