



# PAKISTAN ENGINEERING COUNCIL

## Sample MCQs

### Industrial Electronics

1. Please read all the instructions carefully and do not start the paper unless asked to do so.
2. Fill in your particulars (Name, Roll Number, PEC Registration Number, CNIC and Discipline) in BLOCK letters in the space provided.
3. You are not allowed to change your seat during the test.
4. Hand over your answer sheet to the invigilator at the end of each part and keep seated until allowed to leave the centre.
5. The examination is divided into three Parts viz Part-I, Part-II and Part-III, with 30 minutes break.
6. All questions are to be attempted and carry equal marks.
7. Passing marks for each part is 60%, and passing all three parts is mandatory to qualify EPE.
8. Use only the provided pencil to fill completely the correct choice circle on answer sheet.
9. Programmable calculator, laptop, mobile phone, iPod, and any storage device/electronic gadget are not allowed.
10. No extra sheet will be provided; any calculation may be worked out on the back of the paper.
11. No candidate is allowed to indulge in any Law and Order situation to affect the exam process, and responsible(s) will be disqualified.
12. Use of unfair means will also lead to disqualification.

#### Instructions for Part-I

This part is common to all disciplines, comprising 30 multiple choice questions of one mark each (Total Marks=30) with the duration of two hours.

#### Instructions for Part-II

This is a discipline based open book breadth examination, comprising 30 multiple choice questions of one mark each (Total Marks=30), with the duration of two hours.

#### Instructions for Part-III

This is a discipline based open book depth examination comprising 40 multiple choice questions of one mark each (Total Marks=40), with duration of three hours. The candidates will be allowed only for the specialized field / area of practice, for which already applied at the time of application.

# Industrial Electronics

## Part-I

**Total Marks: 30**

**Total Time: 2 hours**

<b>Name:</b>	<b>S/o, D/o, w/o:</b>
<b>Roll Number:</b>	<b>PEC Reg#:</b>
<b>CNIC:</b>	<b>Discipline:</b>

---

**Q.1:** Quality control is aimed at:

- a. Maintaining the desired quality
- b. Exceeding the desired quality
- c. Continuously improving the quality
- d. Following the quality

**Q.2:** Which of these is correct with respect to a product developed or a service performed?.

- a. Bad quality is acceptable, but bad grade is not.
- b. Bad grade is acceptable, but bad quality is not.
- c. Neither bad grade nor quality is acceptable.
- d. Grade and quality is the same thing.

**Q.3:** Project A has an internal rate of return (IRR) of 21 percent. Project B has an IRR of 7 percent. Project C has an IRR of 31 percent. Project D has an IRR of 25 percent. Which of these would be the BEST project?

- a. Project A
- b. Project B
- c. Project C
- d. Project D

**Q.4:** What characteristic best describes the cost baseline?

- a. Total budget for the project
- b. Time phased budget for the project
- c. Total budget for the project including the contingency budget

- d. Total budget for the project including the contingency budget and the management reserve.

**Q.5:** Present worth is:

- a. The discounted future cash flows to the present
- b. The compounding present cash flows to the future
- c. The current market value of the investment
- d. The opportunity cost at the present value.

**Q.6:** The first preferred way to resolve a dispute between the contracting parties is:

- a. Arbitration
- b. Litigation
- c. Negotiation
- d. Mediation

**Q.7:** Following document define the legal rights and obligations of the parties and may be described as the regulations under which the contract will be performed.

- a. Specifications
- b. General Conditions of Contract
- c. Special provisions
- d. Bill of Quantities

**Q.8:** The minimum notice period for National Competitive bidding is:

- a. 30 days
- b. 45 days
- c. 35 days
- d. 15 days

**Q.9:** Tsunamis' is generated by:

- a. Earthquake
- b. Air currents
- c. Tidal waves
- d. Large Ocean waves

**Q.10:** Globalization has direct impact on:

- a. National security
- b. Economy
- c. Society
- d. All above

**Q.11:** The passive voice for the sentence "He is writing a letter" is;

- a. A letter is wrote by him
- b. A letter is written by him
- c. A letter is being written by him
- d. A letter is been written by him

**Q.12:** Choose the correct sentence

- a. He is elder than me
- b. He is older than me
- c. He is ager than me
- d. He is older than I

**Q.13:** Effective communication is

- a. The transfer of message from sender to receiver
- b. Sending of message
- c. Receiving of message
- d. The transfer of message from sender to receiver and get the desired response.

**Q.14:** Body language is form of;

- a. Personality and attitudes
- b. Non verbal communication
- c. Individual preference for expression
- d. The body expression

**Q.15:** Project feasibility report is aimed at;

- a. Informing the people
- b. Attracting the customer
- c. Justifying the investment
- d. Giving details of resources

**Q.16:** Research Proposal synopsis is developed at;

- a. Final stage of research
- b. Initial stage of research
- c. Before approval of research proposal
- d. In the middle of research

**Q.17:** Project monitoring is required:

- a. Before commencement of the project
- b. During implementation of the project
- c. After completion of the project
- d. At any stage of the project deemed necessary

**Q.18:** Re-appropriation Statement is form of

- a. Progress report
- b. Budget report
- c. Financial report
- d. Normal report

**Q.19:** PC-III (A) is used for

- a. For weekly progress report of public sector projects
- b. Monthly progress report of public sector projects
- c. Yearly progress report of public sector projects
- d. Quarterly progress report of public sector projects.

**Q.20:** Acquiring management and leadership skills are \_\_\_\_\_ for a Professional Engineer

- a. Wastage of time
- b. Not important
- c. Highly important
- d. Not necessary

**Q.21:** Engineering ethics refers to:

- a. The rules and standards given by an institution for Engineering practice
- b. The rules and regulation relating to obligations and rights of others.
- c. The professional regulation
- d. The rules and standards which govern the conduct of Engineers as professional Engineers.

**Q.22:** How many commandments are given in PEC Code of Ethics?

- a. 20
- b. 30
- c. 10
- d. 05

**Q.23:** As per PEC Code of Conduct a member shall report unethical professional practices of an engineer or a member with substantiating data to

- a. Court of Law
- b. Concerned Department
- c. Pakistan Engineering Council
- d. Law enforcing Agency

**Q.24:** When a member uses designs, plans, specifications, data and notes supplied to him by a client or an employer or are prepared by him in reference to such client or the employer's work such designs, plans, specifications, data and notes shall remain the property of the \_\_\_\_\_ and shall not be duplicated for any use without the express permission of the \_\_\_\_\_.

- a. Member, Member
- b. Client, Client
- c. Member, Client
- d. Client, Member

- Q.25:** As per PEC Code of Conduct to maintain, uphold and advance the honor and dignity of the engineering professional, a member shall do following except:
- uphold the ideology of Pakistan
  - be honest, impartial and serve the country, his employer, clients and the public at large with devotion.
  - Uphold personal interest first
  - use his knowledge and skill for the advancement and welfare of mankind
- Q.26:** Conflicts are faced when:
- There are more than one expected outcomes
  - There are more than one expected benefits and losses
  - There is choice between two or more moral values each having its own merits.
  - There are opposing outcomes.
- Q.27:** An example of a conflict of interest would be:
- As a responsible official you make a decision about a contract award that will benefit you personally
  - You and a functional manager disagree with a task cost estimate
  - Your sponsor decides to cancel your project because it no longer supports the company strategy
  - Your personality conflicts with that of a key member of your project team.
- Q.28:** Adherence to professional ethics is \_\_\_\_\_ an engineer to society.
- Not obligation of
  - An obligation of
  - Optional for
  - None of above
- Q.29:** While designing a project by an engineer, \_\_\_\_\_ should be taken into account to protect cultural heritage
- All possible alternates
  - No protection
  - Minimum protection
  - No care
- Q.30:** Close interpersonal relationships are characterized by high intimacy whereas distressed relationships tend to involve reciprocation of \_\_\_\_\_ behaviour.
- positive
  - negative
  - normal
  - casual

## Answers:

1. a
2. b
3. c
4. b
5. a
6. c
7. a
8. d
9. a
10. d
11. c
12. b
13. d
14. b
15. c
16. c
17. b
18. c
19. b
20. c
21. d
22. c
23. c
24. b
25. c
26. c
27. a
28. b
29. a
30. b

## Part-II (Breadth of discipline)

Total Marks: 30

Total Time: 2 hours

Q.1: Which of the following is a hyperbola ?

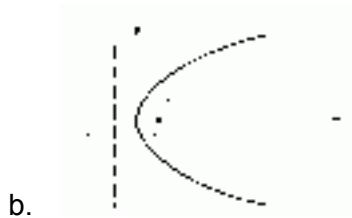
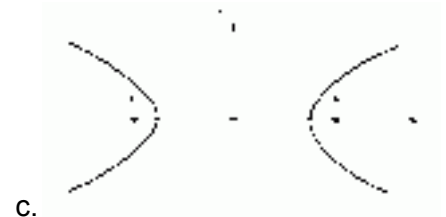
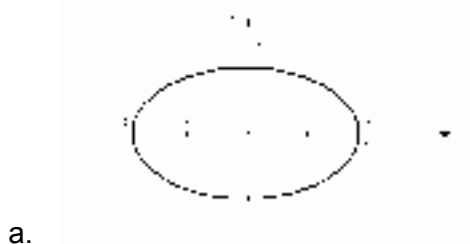

d. None of the above

Q.2: Integrating  $\int \frac{\ln\left(\frac{1}{x}\right)}{x^2} dx$  will result in

- a.  $\frac{1}{x} \ln\left(\frac{1}{x}\right) - \frac{1}{x} + c$
- b.  $\frac{1}{x} + c$
- c.  $-\left(\frac{1}{x} \ln\left(\frac{1}{x}\right) - \frac{1}{x}\right) + c$
- d. None of the above

Q.3: An  $n \times n$  matrix is said to be symmetric if;

- a. If it is equal to its transpose
- b. If its determinant is equal to zero
- c. If it is of 2<sup>nd</sup> order
- d. None of the above

Q.4: Mathematically, what is a differential?

- a. A technique used for mathematical modeling.
- b. A method of directly relating how changes in an independent variable affect changes in a dependent variable.
- c. A method of directly relating how changes in a dependent variable affect changes in an independent variable.



d. None of the above

**Q.5:** The maximum current will pass through

- a. Resistance
- b. Inductance
- c. Capacitance
- d. None of above

**Q.6:** An element which consumes energy instead of storing in it is

- a. Resistor
- b. Inductor
- c. Capacitor
- d. Conductor

**Q.7:** A 1000W heater is rated to operate at a direct current (DC) of 10A. If the heater is supplied alternating current (AC) for producing the same quantity of heat the value of current should be

- a.  $i_{av}=10A$
- b.  $I_{rms}=10A$
- c.  $I_{peak}=10A$
- d.  $I_{rms}=10\sqrt{2}A$

**Q.8:** A fixed resistance 'R' is connected across a dc voltage source. If the voltage is gradually and uniformly increased, the relationship between V and R is correctly represented in which group

- a. Fig(A)
- b. Fig(B)
- c. Fig(C)
- d. Fig(D)

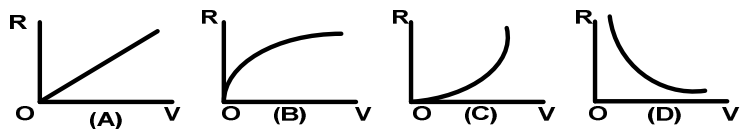

**Q.9:** The effects due to electric current are:

- I. Magnetic effect
- II. Heating effect
- III. Luminous effect

Application working on which effect can be used on AC as well as DC supply?

- a. I only
- b. II only
- c. II and III only
- d. I, II only

**Q.10:** The root locus of a unity feed-back system is shown in fig. The open loop transfer function is given by:

- a.  $k/s(s+1)(s+2)$
- b.  $k(s+1)/s(s+2)$
- c.  $k(s+2) / s(s+1)$
- d.  $ks / (s+1) (s+2)$

**Q.11:** A certain common-emitter amplifier has a voltage gain of 100. If the emitter bypass capacitor is removed.

- a. The circuit will become unstable
- b. The voltage gain will decrease
- c. The voltage gain will increase
- d. The circuit will become stable

**Q.12:** A Darlington transistor connection provides a transistor having a very large

- a. Current gain
- b. Voltage gain
- c. Impedance gain
- d. Impedance matching gain

**Q.13:** What is wrong with this circuit?

- a. The zener is open
- b. The zener is shorted
- c. Nothing
- d. Not enough data

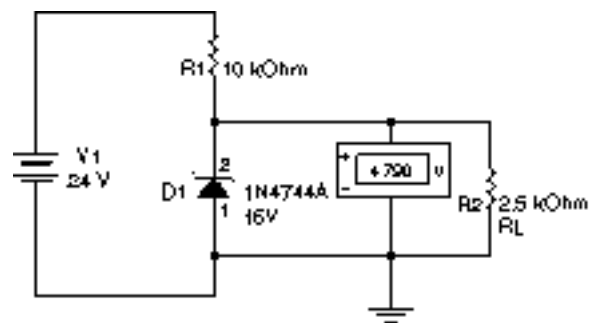

**Q.14:** An oscillator that uses a tapped coil to obtain the feedback is called:

- a. A Hartley circuit
- b. A Pierce circuit

- c. A multivibrator
- d. A negative feedback circuit

**Q.15:** If the output filter capacitor in a power supply actually had a value twice its stated value, which of the following symptoms would be found?

- a. The output voltage would be doubled and a small improvement in the ripple voltage would be detected.
- b. The ripple voltage would be half of what is expected and a small increase in the output voltage would be detected.
- c. The output and ripple voltage would be greater than expected.
- d. The output and ripple voltage would be less than expected.

**Q.16:** What is the simplified version of the signal flow graph represented below?

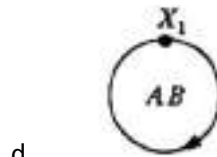
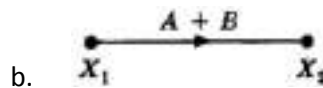
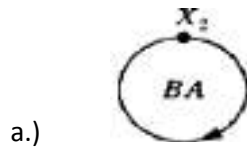
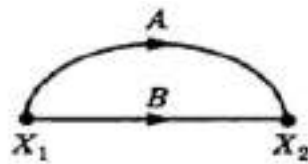



**Q.20:** Frequency is inherently a physical quantity with characteristics.

- a. Positive
- b. negative
- c. both a &b
- d. none of above

**Q.21:** If  $x(n) = \{1, 2, 5, 7, 0, 1\}$  then its region of convergence (ROC) will be:

- a. Entire plane
- b. Entire plane except  $Z=0$
- c. Entire plane except  $Z=0$  and  $Z= \infty$
- d. None of the above

**Q.22:** Which losses in a transformer varies significantly with load

- a. Hysteresis losses
- b. Eddy current losses
- c. Copper losses
- d. Core losses

**Q.23:** Consider the circuit shown in the given figure. For maximum power transfer to the load, the primary to secondary turn's ratio must be

- a. 9 : 1
- b. 3 : 1
- c. 1 : 3
- d. 1 : 9

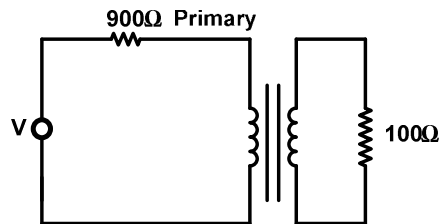

**Q.24:** A lamp of 100W at 200V is supplied current at 100 volts. It will be equivalent to the lamp of:

- a. 50W
- b. 40W
- c. 25W
- d. 10W

**Q.25:** The CPU structure contains:

- a. Cache, ALU, Control Unit and Control Memory
- b. System Bus, ALU, Control Unit and Registers
- c. Memory, ALU, Control Unit and Cache
- d. Registers, ALU, Internal CPU Interconnection and Control Unit

**Q.26:** Clock Speed of which Intel microprocessor is 3 GHz?

- a. Core 2 Duo
- b. Core 2 Quad
- c. Pentium 4
- d. Pentium III

**Q.27:** Normally, the FPGA resources are used less than 70% because:

- a. Routing becomes excessively complicated
- b. Power issues
- c. Clock frequency
- d. Simulation time increases

**Q.28** In which layer Telnet and FTP works?

- a. Application
- b. Session
- c. Network
- d. Physical

**Q.29:** As we know when there is a joint in optical fiber then there will be some loss then this loss be minimized by

- a. Using index matching fluid in the gap
- b. Making V-grooved splicing
- c. Both (a) and (b)
- d. Making carefully polishing

**Q.30:** Fast fading occurs if the channel \_\_\_\_\_ changes rapidly within the symbol duration.

- a. Bandwidth
- b. Frequency

- c. Impulse response
- d. None of the above

## Answers:

1. c
2. c
3. a
4. c
5. c
6. a
7. b
8. a
9. c
10. a
11. b
12. a
13. a
14. a
15. b
16. b
17. c
18. a
19. c
20. a
21. c
22. c
23. a
24. c
25. d
26. b
27. a
28. a
29. a
30. c



# Part-III (Depth: Industrial Electronics)

Total Marks/ MCQs: 40

Total Time: 3 hours

(Sample MCQs = 20)

**Q.1:** The heat generated in the transformer is dissipated to the surroundings mainly by

- a. conduction
- b. convection
- c. radiation
- d. all of the above

**Q.2:** The primary coil of an ideal transformer is connected to an AC voltage source as shown. There are 50 turns in the primary and 200 turns in the secondary. If  $V_1 = 120$  V, what is the potential drop across the resistor R ?

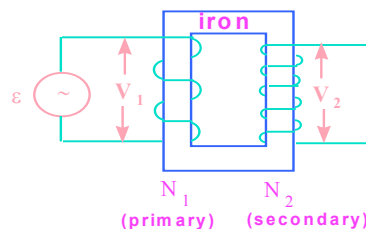

- a. 30 V
- b. 120 V
- c. 480 V
- d. 1920 V

**Q.3:** Using a power supply of 12 volts, what current limiting resistor should be chosen to deliver 1 amp of current to a stepper motor with a coil resistance of 5 ohms? Assume 2 volt drop due to the transistors.

- a. 5.5 ohms
- b. 5 ohms
- c. 4.5 ohms
- d. 4 ohms

**Q.4:** A B-H loop for a type of electric steel sheet is shown in the diagram below. Determine approximately the hysteresis loss per cycle in a torus of 300 mm mean diameter and a square cross section of 50X50 mm.

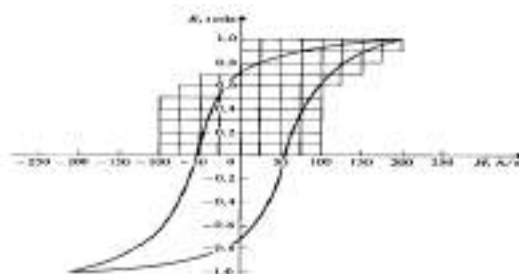

- a. 215 J/m<sup>3</sup>

- b. 0.507 J
- c. 215 J/m<sup>2</sup>
- d. 0.507 J/m<sup>3</sup>

**Q.5:** A UJT exhibits a negative resistance region:

- a. before the peak point
- b. between the peak and the valley points
- c. after the valley point
- d. in respect of both (a) and (b)

**Q.6:** The rms value of current flowing through an SCR when connected across a 325 sine(314t) volts a.c. supply is 18A. The power rating of SCR.....

- a. 9.12 W
- b. 9.12 mW
- c. 9.12  $\mu$ W
- d. 9.12 kW

**Q.7:** Which of the following circuits cannot be operated directly from the mains:

- a. Bridge rectifier.
- b. Centre-tap rectifier
- c. Half-wave rectifier
- d. Voltage doubler

**Q.8:** Figure below is ----- convertor circuit for SMPS

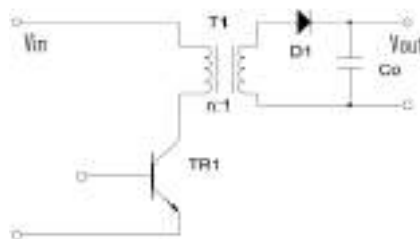

- a. Chopper
- b. flyback
- c. Boost
- d. Buck

**Q.9:** How many joules does a 100 W soldering iron expend in 5 seconds:

- a. 500 J

- b. 3000 J
- c. Cannot be determined
- d. 20 J

**Q.10:** For providing smooth running and controlled acceleration an armature voltage controlled circuit employs.

- a. a comparator
- b. a ramp unit
- c. a phase control circuit
- d. a thyristor bridge

**Q.11:** The diagram below shows a closed-loop control system. What element is represented by the circle labeled X?

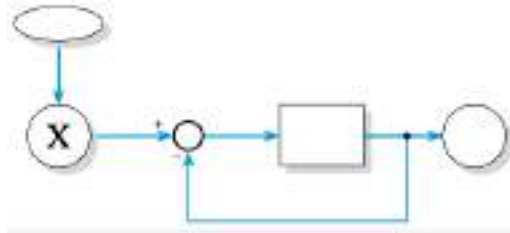

- a. The goal
- b. The user
- c. The error signal.
- d. The forward path

**Q.12:** Photovoltaic emf of a semiconductor photodiode is that voltage at which the resultant current flowing through the device becomes

- a. minimum
- b. maximum
- c. zero
- d. twice the value of the normal current

**Q.13:** A device or tool connected to the end of a robot arm is called:

- a. joint
- b. axis
- c. links
- d. end effector

**Q.14:** Suppose a stiff cardboard carton weighing 10 lb is held in a gripper using friction against two opposing fingers. The coefficient of friction between the finger contacting surfaces and carton surface is 0.25. The orientation of carton is such that the weight of the carton is directed parallel to figure surfaces. A fast work cycle is anticipated so that a g factor of should be applied to calculate required gripper force. Determine the required gripper force for condition given (use factor of safety 1.5).

- a. 60 lb
- b. 90 lb
- c. 120 lb
- d. 150 lb

**Q.15:** A stepping motor has  $N = 250$ ,  $p = .3''/\text{rev}$ . If  $n = 2250$  pulses, what is the distance traveled in the x-direction? What would be the pulse frequency for a travel speed of 16 in./min?

- a. 2.7"
- b. 3"
- c. 3.5"
- d. 1.7"

**Q.16:** In immersion testing you would normally position the:

- a. entrance echo on the right edge of the CRT.
- b. entrance echo on the left of the CRT.
- c. first backwall on the right edge of the CRT.
- d. none of the above

**Q.17:** It is the..... value of the difference between the measured value and the true value of a quantity.

- a. Relative error
- b. Absolute error
- c. Random error
- d. Sequential error

**Q.18:** ----- is a dimensionless parameter that determines the behavior of viscous flow patterns.

- a. specific Gravity
- b. Reynolds number
- c. Pascal
- d. Bernoulli's

**Q.19:** ..... is the tangential force per unit area required to move one horizontal plane with respect to the other at unit velocity when maintained a unit distance apart by the fluid.

- a. Potential viscosity
- b. kinematic viscosity
- c. absolute viscosity
- d. none of above

**Q.20:** .....is the standard for "smart sensors":

- a. IEEE 1073
- b. IEEE 1073.2.1.2
- c. IEEE 1451
- d. IEEE 1073.3.2

## Answers:

1. b
2. c
3. b
4. b
5. b
6. d
7. b
8. b
9. a
10. b
11. a
12. c
13. d
14. b
15. a
16. b
17. b
18. b
19. c
20. c